

Holders for Sensors HT-SE

Sensor connection from 12 to 30 mm

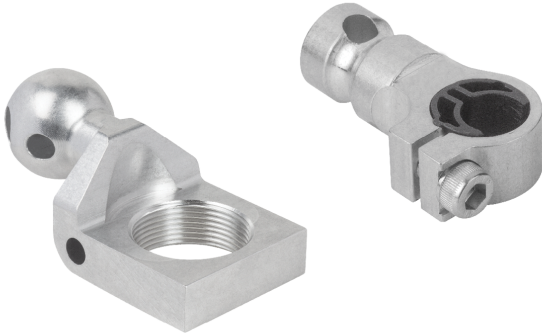

Holders for Sensors HT-SE

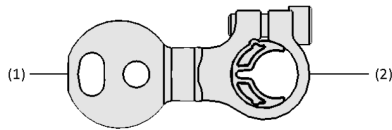

System design Holders for Sensors HT-SE



Holders for sensors HT-SE for mounting a sensor

Suitability for industry specific applications

Application

- Holder for mounting cylindrical sensors on tooling beams
- For sensors with diameters of 12 to 30 mm

Design

- Connection for tooling beams: Ball (A3: \varnothing 28.5 mm; A5: \varnothing 32 mm) or "Apple-Core" cylinder (A2: \varnothing 19 mm) (1)
- Connection for cylindrical sensors (2)

Product highlights

- Flexible use on tooling traverses, fast exchange and short set-up times
- Thanks to lightweight aluminium construction suitable for dynamic processes and high throughputs
- Very versatile, as it is suitable for cylindrical sensors from 12 to 30 mm

Holders for Sensors HT-SE

Sensor connection from 12 to 30 mm

Designation code Holders for Sensors HT-SE

HT-SE	-	A2	-	42	-	30.1
1		2		3		4

1 – Abbreviated designation

Code	Type
HT-SE	Holder for sensors
HT-SE-U	Holder for sensors, universal

2 – Tooling connection

Code	Connection in mm
A2	ø 19, pin
A3	ø 28.5, ball
A5	ø 32, ball

3 – Width

Code	Width in mm
25	25
42	42

4 – Connection

Code	Connection
30.1	30.1 mm
12/18	Variable, 12 or 18 mm
M18x1	M18x1

The holders for sensors HT-SE are delivered as a ready-to-connect product.

Ordering data Holders for Sensors HT-SE

Type	Part no.
HT-SE A2 25 M18x1	10.07.06.00471
HT-SE A2 42 30.1	10.07.06.00468
HT-SE A3 25 M18x1	10.07.06.00469
HT-SE A3 42 30.1	10.07.06.00466
HT-SE A5 25 M18x1	10.07.06.00470
HT-SE A5 42 30.1	10.07.06.00467
HT-SE-U A2 12/18	10.07.06.00482
HT-SE-U A3 12/18	10.07.06.00352
HT-SE-U A3 13.2/18	10.07.06.00779
HT-SE-U A5 12/18	10.07.06.00481

Technical data Holders for Sensors HT-SE

Type	Weight [g]
HT-SE A2 25 M18x1	53
HT-SE A2 42 30.1	64
HT-SE A3 25 M18x1	67
HT-SE A3 42 30.1	78
HT-SE A5 25 M18x1	78
HT-SE A5 42 30.1	89
HT-SE-U A2 12/18	37
HT-SE-U A3 12/18	52
HT-SE-U A3 13.2/18	51
HT-SE-U A5 12/18	63

Holders for Sensors HT-SE

Sensor connection from 12 to 30 mm

Design data Holders for Sensors HT-SE

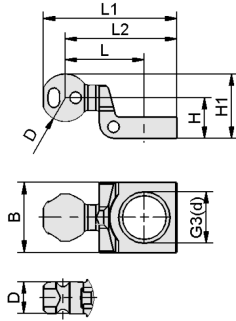

HT-SE

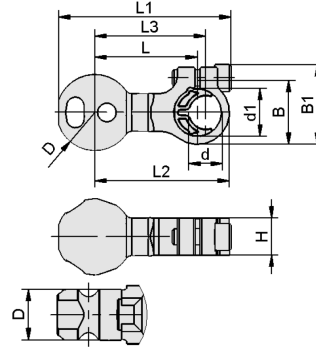

HT-SE U

Holders for Sensors HT-SE

Sensor connection from 12 to 30 mm

Design data Holders for Sensors HT-SE

Type	B [mm]	B1 [mm]	D [mm]	d [mm]	d1 [mm]		H [mm]	H1 [mm]	L [mm]	L1 [mm]	L2 [mm]	L3 [mm]
HT-SE A2 25 M18x1	25	-	19.0	-	-	M18x1-F	24.5	34	41.3	73	61	-
HT-SE A2 42 30.1	42	-	19.0	31	-	-	24.5	34	41.3	73	61	-
HT-SE A3 25 M18x1	25	-	28.5	-	-	M18x1-F	24.5	39	47.5	80	67	-
HT-SE A3 42 30.1	42	-	28.5	31	-	-	24.5	39	47.5	80	67	-
HT-SE A5 25 M18x1	25	-	32.0	-	-	M18x1-F	24.5	41	47.5	82	67	-
HT-SE A5 42 30.1	42	-	32.0	31	-	-	24.5	41	47.5	82	67	-
HT-SE-U A2 12/18	24	30	19.0	12	18	-	14.0	-	34.0	55	46	38
HT-SE-U A3 12/18	24	30	28.5	12	18	-	14.0	-	38.5	65	51	42
HT-SE-U A3 13.2/18	-	-	-	14	18	-	-	-	64.5	-	-	-
HT-SE-U A5 12/18	24	30	32.0	12	18	-	14.0	-	38.5	67	51	42